

# **San Joaquin Council of Governments**

## **I-5 North HOT Lane Review**

Technical Working Group Meeting #2

# Agenda

1. HOT Lane Costing
2. Travel Forecasts
3. HOT Lane Options to be Tested

# Three Kinds of Costs for I-5 North HOT Lane

- Capital Costs
- Operating & Maintenance
- Centralized Services

# Capital Costs

- Recommend use of MTC HOT lane capital costs for upgrading from an HOV lane (accepted for preliminary estimates by Caltrans District 04) – see handout
- Low, medium, and high unit costs developed for the Bay Area should be used for I-5 North – application to be discussed in site review and meeting with Rajappan & Meyer
  - Low level: No structures modifications; no enforcement area; 20% contingency
  - Mid level: Some structures modifications; more CMS/VMS; 30% contingency
  - High level: Significant structures modifications; some sound wall modifications; 40% contingency
- Need consideration of HOV costs
- Request Caltrans District 10 review

# HOT Lane Assumptions Key to Capital Costing

- HOT lanes separated from adjacent general purpose lane by painted yellow lines and 4' buffer
- Where ROW permits, use 12' for HOT lane; narrow GP lanes if necessary
- Seek 14' median shoulder; use width for enforcement in places and weave lanes at spot locations
- Widening may be needed for electronic toll pricing gantries, enforcement areas, and weaving lanes
- Average distance between ingress locations would be 3 to 4 miles

# Conceptual schematic of limited access HOT lane alternative – Preliminary Approach (based on MTC)

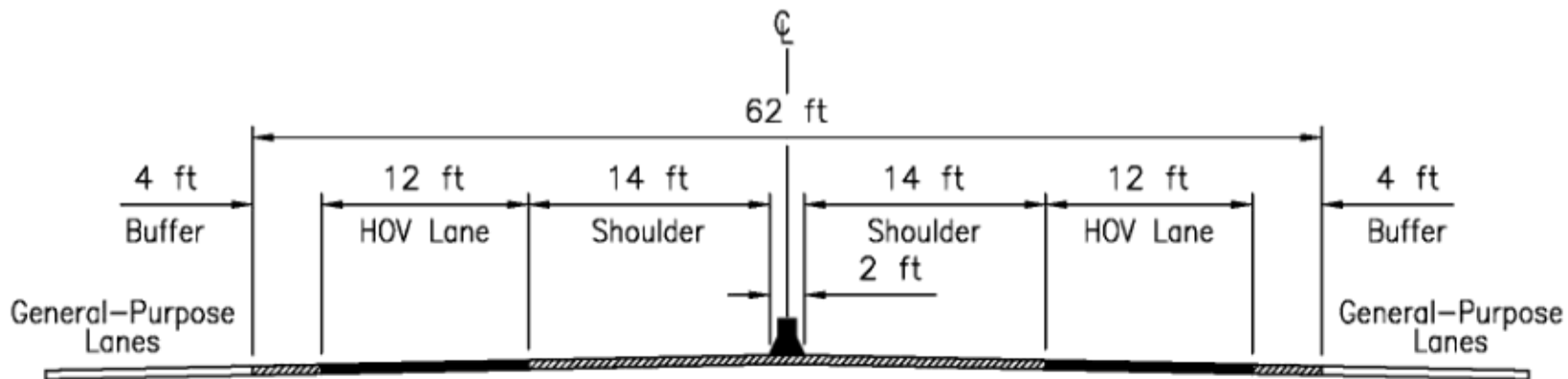

DESIRABLE

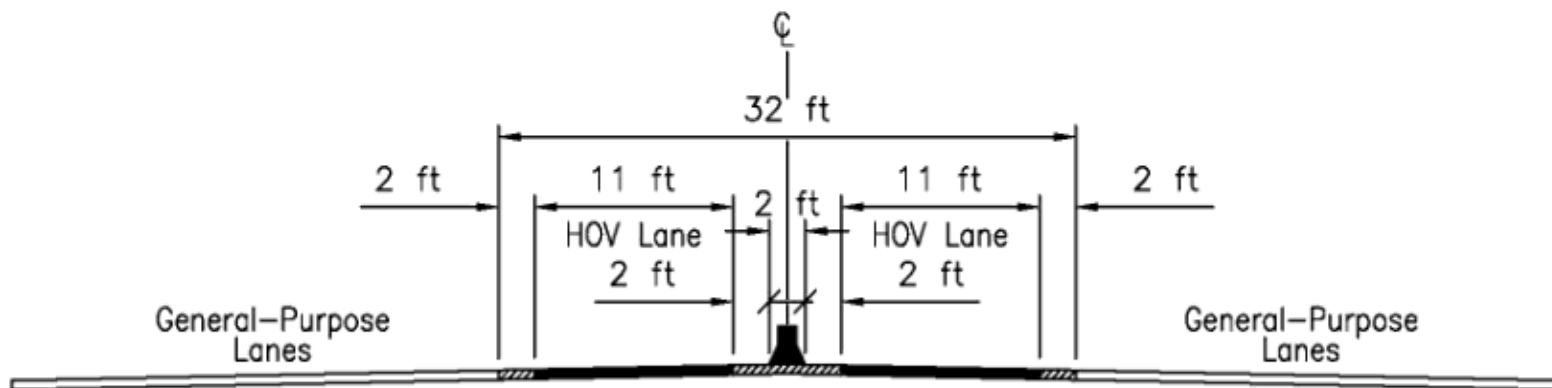

MINIMUM<sup>1</sup>

<sup>1</sup> Operational treatments should be incorporated if the minimum design cross sections are used

# Operations and Maintenance Costs

*(Based on ACCMA I-680 Project)*

- ACCMA O&M costs per lane mile
  - Toll equipment maintenance \$ 15,490
  - Enforcement \$ 16,900
  - Oversight/reporting \$ 5,280
  - Administration and marketing \$ 28,520
  
  - Total \$ 66,190
  
- MTC O&M costs per lane mile
  - \$70,000

## Centralized Services Costs

*Based on MTC/BATA Estimates and assumes BATA acceptance of serving SJCOG HOT Lanes*

- \$ TBD upgrade to BATA system  
(associated with extending Bay Area system to San Joaquin County)
- \$0.16 per transaction
- 2.2% of transaction costs as financing fees
- \$18 per Fastrak transponder

# Travel Forecasts

- Forecasts to be reviewed by Eddie Barrios of Fehr & Peers Associates

# HOT Lane Options To Be Tested

- Policy Options Evaluation Tool (POET)
  - Sketch Planning-Level Tool
  - FHWA-Sanctioned & Developed Tool
  - A Number of Parameters We Can Modify
  - “What If?” Tests on September 22<sup>nd</sup>

# Parameters That Can Be Modified...

## Model Input Page

On this page, the user can select a specific HOV facility from a national database that includes information on policy details and physical characteristics. The user is then required to enter the number of HOV lanes and GP lanes in each direction during peak period operations as well as the corresponding volumes in these lanes. Optional user entry includes the volumes of other applicable vehicle types. Once valid values are entered for these items, the user can continue with the analysis. It is also possible to store a specific profile for future use by modifying the text for one or more of the input data field records.

### Input Data Field

State / Province	
City / County	
Urban Area	
Road	
Segment (From - To)	

Load Record

HOME

Store Profile

PRINT

### General Information

State / Province	
City / County	
Urban Area	
Road	
Segment (From - To)	

### Sketch Planning Tool Parameters

Baseline assumptions for these parameters are subject to change based on local knowledge. All values in blue can be modified. Original values can be restored by clicking the "Reset Parameters" button.

HOME

PRINT

RESET PARAMETERS

### HOV Policy

Eligibility HOV	
Eligibility Toll	
Eligibility Motorcycle	
Eligibility Taxi	
Eligibility Special Fuel	
Eligibility Others	
Hours of Operation	

### Highway Capacity Assumption

	Managed Lanes	GP Lanes
Free-Flow Speed (mph)	65	65
Hourly Freeway Capacity Per Lane (vph)	2,200	2,200
Daily Freeway Capacity Per Lane (vph)	35,000	35,000
% of capacity used at LOS C (free-flow)	0.75	0.75
Peak Hour to Daily Conversion Factor	12	12
Avg. Auto Occupancy	n/a	1.10
Bus PCE Factor	3.00	n/a
Bus Occupancy	20	n/a
HOV Split		
HOV2	85%	2.20
HOV3	10%	3.30
HOV4+	5%	4.40

### Mobility Assumption

	0.90				
BPR Curve - Alpha	0.90				
BPR Curve - Beta	3.00				
Level of Service	A	B	C	D	E
Maximum V/C	0.30	0.50	0.75	0.90	1.00
Maximum Service Flow Rate (pc/h/ln) - HOV	660	1100	1650	1980	2200
Maximum Service Flow Rate (pc/h/ln) - GP	660	1100	1650	1980	2200
Minimum Speed (mph) - HOV	63	58	47	39	34
Minimum Speed (mph) - GP	63	58	47	39	34
Volume Contribution to HOT Lanes (From GP)	30%	40%	50%	60%	70%
Volume Contribution to HOT Lanes (From Parallel Facilities)	70%	60%	50%	40%	30%

# Parameters That Can Be Modified...

- Facility-Related Capacity
  - General Purpose Lanes ~ 2200 vph
  - HOV/HOT Lane ~ 1650 vph (LOS C)
- Peak to Daily Conversions
  - Factor of 12
- Eligibility Policies
  - Motorcycles, Taxis, LEVs, Others
  - # Public Transportation Vehicles
- HOV “Split” (85% 2, 10% 3, 5% 4+)

# Parameters That Can Be Modified...

- HOT Factors
  - Eligibility Reqmnts: 2+ vs. 3+ (*And When?*)
  - Contribution from GP Lanes vs. Parallel Facilities (Varies @ LOS A ~ 30/70% to @ LOS F ~ 70/30%)
- Revenue Estimation
  - Value of Time ~ \$25
  - # work Days/Year ~ 250 (50 Weeks x 5 Days/Week)
  - Weekend Usage as % of Weekday ~ 25%

- Next Steps
  - Meet on 9/22 at 9 AM and Test a Variety of “What If?” Scenarios
  - Compare Revenues to Operating Costs
  - Preliminary Results in real-Time
  - Discussion of Other Elements of HOT Lane Operations and State Policy Development